

**Controller for Adaptive 100/120Hz  
Current Ripple Removing Circuit**

*Parameters Subject to Change Without Notice*

**DESCRIPTION**

JW<sup>®</sup>1251O is a controller for driving external NMOSFET to remove the 100/120Hz LED current ripple on AC/DC power by a capacitor between VC and GND.

The adaptive technology of JW1251O ensures minimum power dissipation on NMOSFET while removing LED current ripple.

Patented control strategies are optimized for dimmable solutions.

JW1251O enables good ripple removing performance in the whole output current range and excellent system dynamic responding speed in the fast dimming.

JW1251O provides short circuit protection and over temperature protection (OTP). OTP is triggered at 145°C, ripple current will be released with the temperature.

*Company's Logo is Protected, "JW" and "JOULWATT" are Registered Trademarks of JoulWatt technology Inc.*

**FEATURES**

- Controller for adaptive 100/120Hz current ripple remover
- Built-in zener diode for input voltage clamping
- Compatible with dimmable applications
- Programmable amplitude of LED current ripple
- Programmable maximum cathode voltage of LED
- Programmable maximum LED current
- Short protection
- Over temperature protection
- SOT23-6 Package

**APPLICATIONS**

- LED lighting

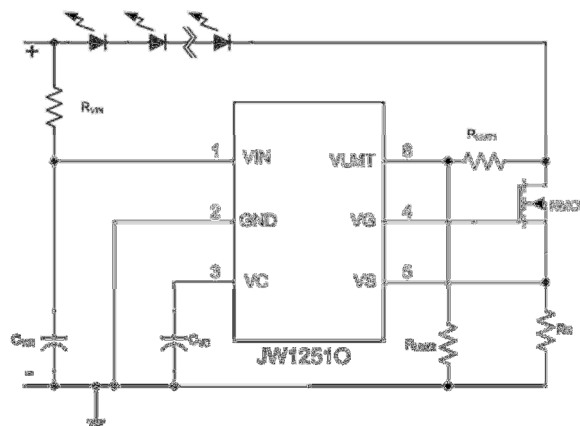
**TYPICAL APPLICATION**

**ORDER INFORMATION**

DEVICE <sup>1)</sup>	PACKAGE	TOP MARKING <sup>2)</sup>
JW12510SOTB#TRPBF	SOT23-6	JWE9□ YW□□□

**Notes:**

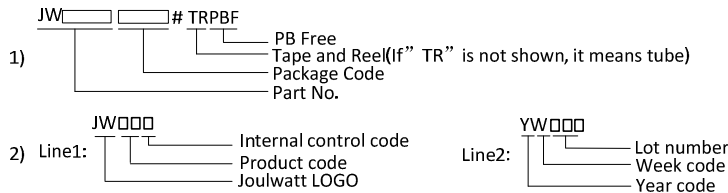

**PIN CONFIGURATION**

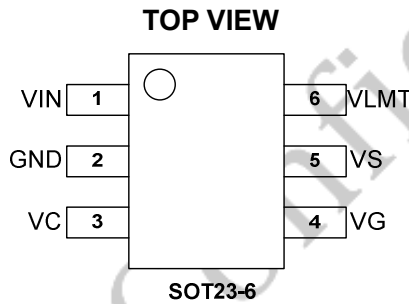

**ABSOLUTE MAXIMUM RATING<sup>1)</sup>**

VIN clamp voltage.....	35V
VG .....	20V
VS, VC, VLMT .....	-0.3V to 6V
Junction Temperature <sup>2)3)</sup> .....	150°C
Lead Temperature .....	260°C
Storage Temperature .....	-65°C to +150°C
ESD Susceptibility (Human Body Model) .....	2kV

**RECOMMENDED OPERATING CONDITIONS**

Junction Temperature (T <sub>J</sub> ).....	150°C
---	-------

**THERMAL PERFORMANCE<sup>4)</sup>**

	$\theta_{JA}$	$\theta_{JC}$
SOT23-6 .....	220	130°C/W

**Note:**

- 1) Exceeding these ratings may damage the device.
- 2) The JW1251O guarantees robust performance from -40°C to 150°C junction temperature. The junction temperature range specification is assured by design, characterization and correlation with statistical process controls.
- 3) The JW1251O includes thermal protection that is intended to protect the device in overload conditions. Thermal protection is active when junction temperature exceeds the maximum operating junction temperature. Continuous operation over the specified absolute maximum operating junction temperature may damage the device.
- 4) Measured on JESD51-7, 4-layer PCB.

JoulWatt Confidential

## ELECTRICAL CHARACTERISTICS

*VIN = 18V, TA = 25°C, unless otherwise stated.*

Item	Symbol	Condition	Min.	Typ.	Max.	Units
VIN clamp voltage	V <sub>IN_CLP</sub>		29	32	35	V
VIN operation current	I <sub>IN</sub>	VIN=29V	0.15	0.225	0.3	mA
VIN startup voltage threshold	V <sub>IN_ST</sub>		7.5	9	10.5	V
VIN UVLO threshold	V <sub>IN_UVLO</sub>		5	6	7	V
Maximum VG output voltage	V <sub>VG</sub>		5	6	7	V
VLMT reference voltage	V <sub>LMTR</sub>		1.85	2.05	2.25	V
SHORT protection threshold	V <sub>TH_SHORT</sub>	Drain voltage of NMOSFET when SHORT is triggered. R <sub>LIMIT</sub> =100K.	5	6	7.5	V
SHORT protection delay time <sup>5)</sup>	TSPD			160		us
SHORT protection hold time <sup>6)</sup>	TSPH			800		ms
VS voltage limit	V <sub>VS</sub>		0.2		0.25	V

**PIN DESCRIPTION**

Pin No.	Name	Description
1	VIN	Power Supply
2	GND	Ground
3	VC	LED Current Ripple Programming
4	VG	NMOSFET GATE driving voltage output
5	VS	LED current sensing input
6	VLMT	LED Voltage Limit and SHORT protection Programming

**BLOCK DIAGRAM**

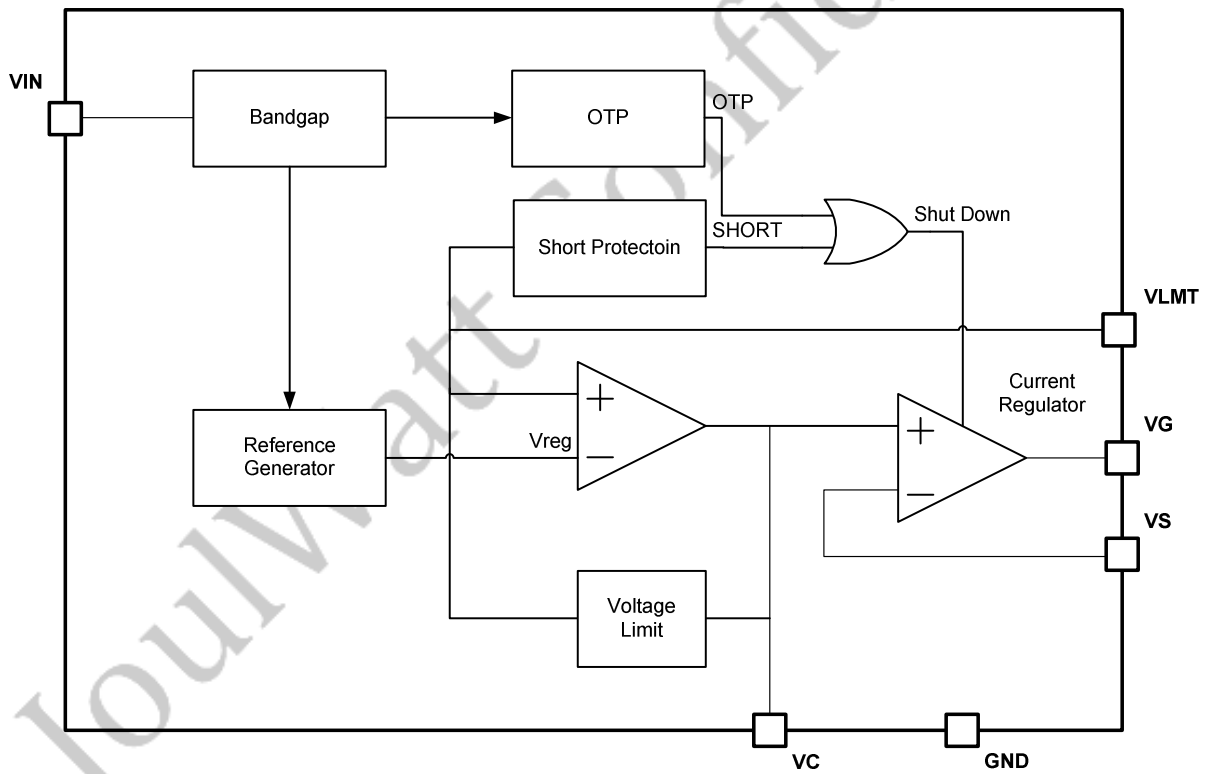



## FUNCTIONAL DESCRIPTION

JW12510 is a controller for driving external NMOSFET to remove the 100/120Hz LED current ripple on AC/DC power.

### Theory of Operation

The LED string and JW12510 are both supplied by an AC/DC current source. The drain of external NMOSFET is connected to the cathode of LED string. A sensing resistor  $R_{SENSE}$  is connected between the source of NMOSFET and GND. The gate is connected to the VG of JW12510.

JW12510 drives NMOSFET to transfer the LED current ripple to voltage ripple on NMOSFET, and ensures the constant voltage across LED string and the current flow through LED string. The scalable adaptive function of JW12510 can regulate the cathode voltage of LED string to minimum to improve the efficiency of the system.

### Current Ripple Removing

The capacitor  $C_C$  between VC and GND is an integration capacitor. JW12510 transform the voltage on  $C_C$  to a reference voltage. The current regulator regulates the voltage on  $R_{SENSE}$  equal to the reference voltage.

The relationship between the voltage on  $C_C$  and  $R_S$  is shown as following:

$$V_{RS} = I_{LED} * R_{SENSE} = V_{VC} / 10 - 0.059$$

$C_C$  should be large enough in order to remove the current ripple of the LED string. However, too large capacitor may slow down the dynamic response.

### Adaptive Regulation

JW12510 control the voltage on  $C_C$  by monitoring the operation state of external NMOSFET. The efficiency of system is relatively

low when NMOSFET is working in the saturation region. JW12510 detects it and charges  $C_C$  to raise the  $V_{VC}$  and  $I_{LED}$ , then the output voltage of power supply is reduced, and the voltage drop on NMOSFET decreases.

Conversely, when NMOSFET is working in the linear region, LED current regulation loop is open. JW12510 detects it and discharges  $C_C$  to reduce the  $V_{VC}$  and  $I_{LED}$ , then the output voltage of power supply is raised, and the LED current regulation loop is close.

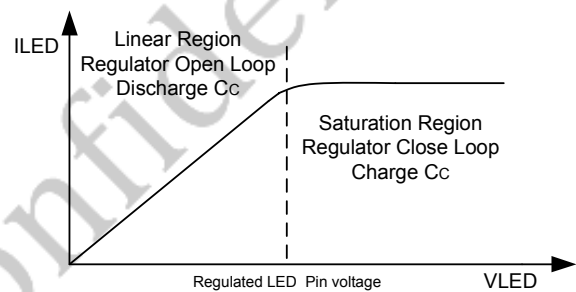

### LED Current Limit

The voltage of VS pin is limited to 0.23V typ. internally. So the current limitation is  $0.23V/R_S$ .

Current limit can protect the chip when LED is short connected or HOT-PLUG.

### LED Short Protection

JW12510 detect SHORT by the resistor divider. When the drain voltage of NMOSFET exceeds the SHORT PROTECTION THRESHOLD and the state holds for more than 160us, JW12510 considers the LED string is SHORT connected, and shut down the external MOSFET. The SHORT state is reset after 800ms.

The SHORT PROTECTION THRESHOLD is calculated as:

$$V_{THSCP} = 2V * (R_{LMT1} + R_{LMT2}) / R2 + R1 * 35uA$$

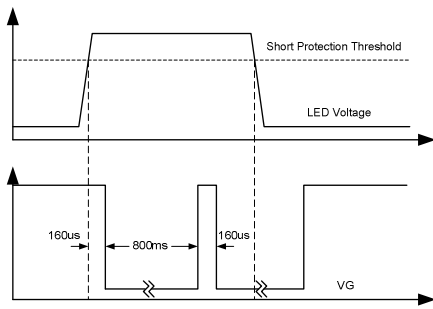

### Over Thermal Protection

JW12510 monitors operation temperature. When the temperature is higher than 145°C,

JW12510 releases the current ripple unless restarts.

### PCB Design Guideline

1. The bypass capacitor of VIN should be placed as close as possible to the VIN pin and GND pin of IC.
2. JW12510 should be placed far away from the power devices such as MOSFET and SBD.
3. The area of LED current loop should be as small as possible.

APPLICATION INFORMATION

JW1251O design guide:

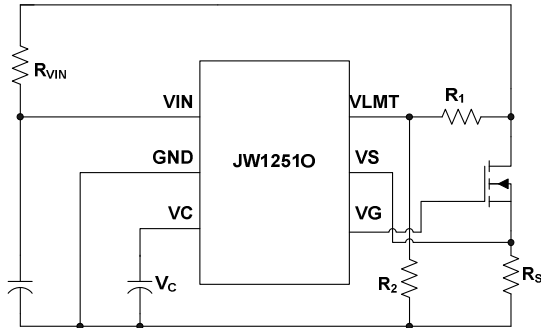

1. Because of the 32V zener integrated and the 9V  $V_{IN}$  start threshold, the value of  $R_{VIN}$  may satisfy the following conditions:

$$R_{VIN} < \frac{V_F - 9V}{1mA}$$

$V_F$ : the voltage of LED

2. The maximum voltage of VS pin is 0.23V in order to limit the maximum output current especially in the short circuit condition. The value of  $R_S$  can be calculated as below:

$$R_S < \frac{0.18V}{I_{LED}}$$

$I_{LED}$ : the output current of the pre-driver

3. When the voltage of LED- reaches  $V_{SCP}$  which is set by the  $R_1$  and  $R_2$ , JW1251O pulls down the  $V_{IN}$  then turns off the MOSFET. In order to ensure nothing will be damaged in the short circuit condition, the value of  $R_1$  and  $R_2$  must satisfy the following

conditions:

$$V_{OVP} - V_F < V_{SCP} < V_F$$

$$V_{SCP} = 2V(R_2 + R_1)/R_2 + 35\mu A * R_1$$

$V_{OVP}$ : the output voltage when the pre-driver is open.

$V_{SCP}$ : the threshold of JW1251O short circuit protection.

$V_{INSTART}$ : the output voltage of the pre-driver when the  $V_{IN}$  of JW1251O is 9V.

4. The value of the capacitor between VC and GND can determine the final amplitude of the current ripple. It should be large enough in order to remove the current ripple of the LED string. However, too large capacitor may slow down the dynamic response. In normal condition, 1uF or 2.2uF is relatively reasonable.
5. To ensure JW1251O work properly, the  $R_{DS(on)}$  of MOSFET must be less than  $2R_S$ . The MOSFET will endure a large power shorting the output on the moment, so the appropriate package and  $R_{DS(on)}$  of the MOSFET is necessary.
6. When short the LED, there is an overshoot on the drain of the MOSFET. The breakdown voltage of the MOSFET must be higher than  $V_{OVP}$ . A diode connected to LED+&LED- can reduce the overshoot when short.

PACKAGE OUTLINE

SOT23-6

UNIT: mm

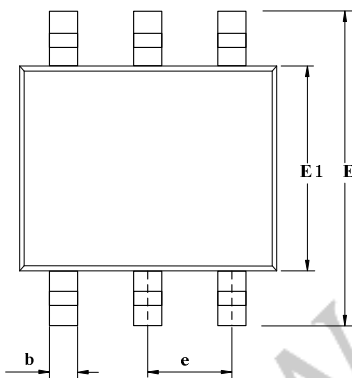
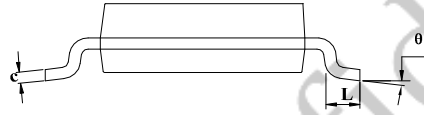
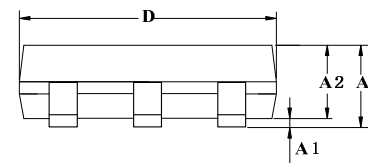

SYMBOL	MILLIMETER		
	MIN	NOM	MAX
A	1.05	1.15	1.25
A1	0	0.05	0.15
A2	0.95	1.10	1.20
b	0.20	0.40	0.60
c	0.05	—	0.21
D	2.72	2.92	3.12
E	2.60	2.80	3.00
E1	1.40	1.60	1.80
e	0.95 (BSC)		
L	0.30	0.45	0.60
θ	0°	—	8°

**IMPORTANT NOTICE**

- Joulwatt Technology Inc. reserves the right to make modifications, enhancements, improvements, corrections or other changes without further notice to this document and any product described herein.
- Any unauthorized redistribution or copy of this document for any purpose is strictly forbidden.
- Joulwatt Technology Inc. does not warrant or accept any liability whatsoever in respect of any products purchased through unauthorized sales channel.

JoulWatt Confidential

*Copyright © 2017 JW12510 Incorporated.*

*All rights are reserved by Joulwatt Technology Inc.*